

FUNCTION BLOCK DESCRIPTION

Line thermal protection function block description





VERSION INFORMATION

VERSION	DATE	MODIFICATION	COMPILED BY
Preliminary	2009-10-30	Preliminary version, without technical information	Petri
	2010-05-10	Naming revision	Csipke
1.0	2010-11-11	First edition	Petri
2.0	2024-07-11	Second edition (new chapters, new look)	Papik, Erdős
3.0	2024-10-10	Changes due to graphical analogue function block added Addition of information about temperature measurement with sensor	Saina
3.1	2025-01-03	<ul style="list-style-type: none"> • Minor corrections • Additional information about the Temperature memory parameter in several chapters • Update of content and figure in chapter 1.3 	Seida

CONTENTS

1	Operation principle.....	4
1.1	Theory of the thermal replica calculations	5
1.1.1	The thermal differential equation	5
1.1.2	The temperature-time function for constant current	5
1.1.3	Formulas for checking the thermal protection function.....	6
1.1.4	Numerical solution of the thermal differential equation	8
1.2	Measurement of the ambient temperature.....	8
1.3	Structure of the line thermal protection	9
1.4	RMS calculation (RMS)	10
1.5	The maximum selection (Max selection)	10
1.6	The temperature calculation and decision (Thermal replica)	11
2	Line thermal protection function overview	12
2.1	Settings	12
2.1.1	Parameters	12
2.2	Function I/O.....	13
2.2.1	Analogue inputs	13
2.2.2	Analogue outputs (measurements)	13
2.2.3	Binary output signals (graphed input statuses)	13
2.2.4	Binary input signals (graphed output statuses)	13
2.2.5	On-line data	14
2.2.6	Events.....	14
2.3	Technical data.....	14
2.4	Notes for testing.....	14

1 Operation principle

Basically, line thermal protection measures the three sampled phase currents. RMS values are calculated, and the temperature calculation is based on the highest RMS value of the phase currents.

The temperature calculation is based on the step-by-step solution of the thermal differential equation. This method yields “overtemperature”, meaning the temperature above the ambient temperature (of the environment). Accordingly, the temperature of the protected object is the sum of the calculated “overtemperature” and the ambient temperature.

The ambient temperature can be measured using e.g. a temperature probe generating electric analog signals proportional to the temperature. In the absence of such measurement, the temperature of the environment can be set using the dedicated parameter *Ambient Temperature*. The selection between parameter value and direct measurement is made by setting the binary parameter *Temperature sensor*. In the second case special HW input module is required. See paragraph 1.2.

If the calculated temperature (calculated “overtemperature”+ambient temperature) is above the threshold values, status signals are generated (parts written in **bold** are seen on the right side of the function block in the *Logic Editor*):

TTR49L_**Alarm**_Grl_

TTR49L_**Trip**_ Grl _

TTR49L_**LockTrip**_ Grl_

For correct setting, the following values must be measured and set as parameters:

<i>Rated load current</i>	Rated load current of the protected line
<i>Rated temperature</i>	The steady state overtemperature at rated load current
<i>Ambient Temperature</i>	The temperature of the environment which shall be considered by the function in lack of ambient temperature measurement
<i>Base Temperature</i>	The temperature of the environment during the measurement of the Time constant and Rated temperature values
<i>Time constant</i>	Measured heating time constant of the exponential temperature function

When energizing the protection device, the algorithm permits the definition of the starting temperature as the initial value of the calculated temperature:

<i>Start-up Temperature</i>	Initial temperature above the ambient temperature as compared to the rated temperature above the base temperature
-----------------------------	---

If, however, the IED has not been being switched off for more time than what is set by the parameter *Temperature memory*, then the function continues to calculate the temperature from the calculated value before deenergizing the device.

The problem of metal elements (the protected line) exposed to the sun is that they are overheated as compared to the „ambient” temperature even without a heating current; furthermore, they are cooled mostly by the wind and the heat transfer coefficient is highly dependent on the effects of the wind. As the overhead lines are located in different geographical environments along the tens of kilometers of the route, the effects of the sun and the wind cannot be considered in detail. The best approximation is to measure the temperature of a piece of overhead line without current but exposed to the same environmental conditions as the protected line itself.

The application of thermal protection of the overhead line is a better solution than a simple overcurrent-based protection because thermal protection “remembers” the preceding load states of the line and the setting of the thermal protection does not need so a high security margin between the permitted current and the permitted continuous thermal current of the line. In a broad range of load states and in a broad range of ambient temperatures this permits the better exploitation of the thermal and consequently current carrying capacity of the line.

1.1 Theory of the thermal replica calculations

1.1.1 The thermal differential equation

The thermal differential equation to be solved is:

$$\frac{d\Theta}{dt} = \frac{1}{T} \left(\frac{I^2(t)R}{hA} - \Theta \right) \quad (1)$$

The definition of the heat time constant is:

$$T = \frac{cm}{hA}$$

In this differential equation:

$I(t)$ (RMS)	heating current, the RMS value usually changes over time;
R	resistance of the line;
c	specific heat capacity of the conductor;
m	mass of the conductor;
θ	rise of the temperature above the temperature of the environment;
h	heat transfer coefficient of the surface of the conductor;
A	area of the surface of the conductor;
t	time.

1.1.2 The temperature-time function for constant current

The solution of the thermal differential equation for constant current is the temperature as the function of time. (2)

$$\Theta(t) = \frac{I^2 R}{hA} \left(1 - e^{-\frac{t}{T}} \right) + \Theta_o e^{-\frac{t}{T}} \quad (2)$$

Remember that the calculation of the measurable temperature is as follows:

$$\text{Temperature}(t) = \Theta(t) + \text{Temp_ambient}$$

where:

Temp_ambient is the ambient temperature.

Instead of the aforementioned parameters some more easily measurable ones can be introduced. Thus, the general form of equation (2) is:

$$H(t) = \frac{\Theta(t)}{\Theta_n} = \frac{I^2}{I_n^2} \left(1 - e^{-\frac{t}{T}} \right) + \frac{\Theta_o}{\Theta_n} e^{-\frac{t}{T}} \quad (3)$$

where:

- H(t) is the „thermal level” of the heated object, **this is the temperature as a percentage of the Θ_n reference temperature**. This is a dimensionless quantity, but it can also be expressed in a percentage form.
- Θ_o is the starting temperature above the temperature of the environment
- Θ_n is the reference temperature above the temperature of the environment, which can be measured in steady state, in case of a continuous I_n reference current.
- I_n is the reference current, can be considered as the nominal current of the heated object. If it flows continuously, then the reference temperature can be measured in steady state.

1.1.3 Formulas for checking the thermal protection function

Equation (3) offers a general formula to check the operation of the thermal protection using constant current.

The changes of temperature over time, described by equation (3), are plotted in the diagram below. Parameter is the starting temperature related to the reference temperature $\frac{\Theta_o}{\Theta_n}$

Figure 1-1 H(t) diagrams of the line thermal protection function

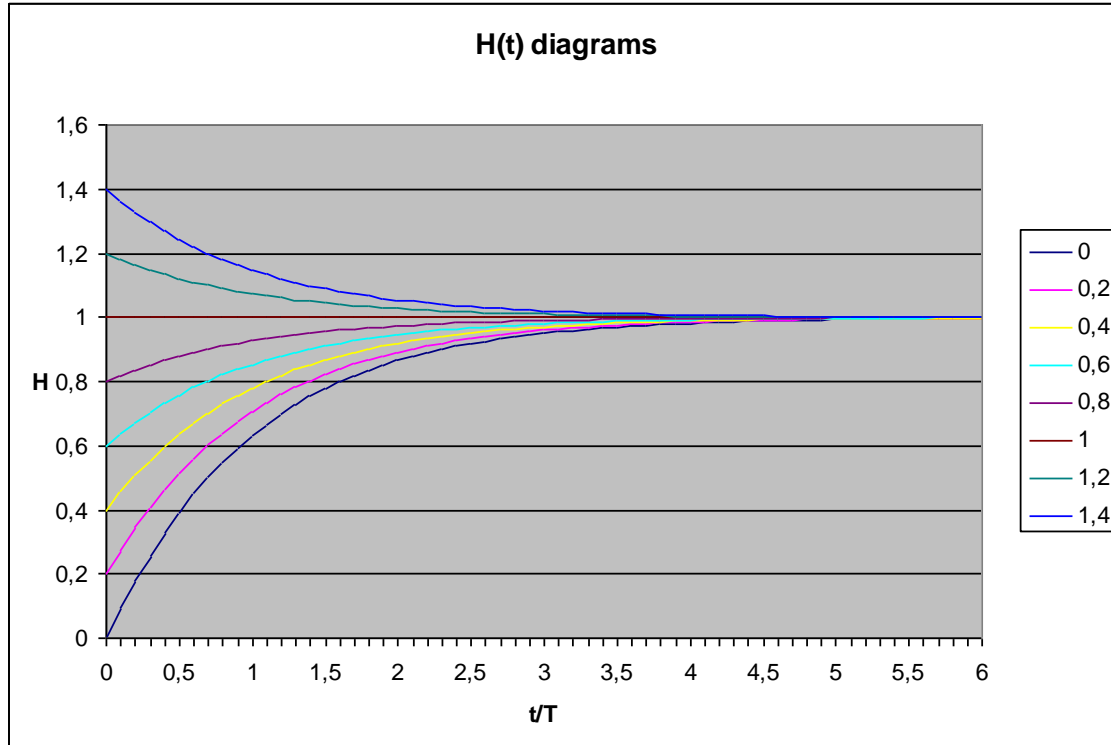

For further tests, the time needed to reach a specific temperature value can be calculated based on equation (3). The derived formula with relative quantities is:

$$\frac{t}{T} = \ln \left(\frac{\frac{\Theta_S}{\Theta_n} - \frac{\Theta_o}{\Theta_n}}{\frac{\Theta_S}{\Theta_n} - \frac{\Theta_{set}}{\Theta_n}} \right) \quad (4)$$

where:

$\Theta_S = \frac{I^2 \Theta_n}{I_n^2}$ is the steady state temperature in case of continuous I current,

Θ_{set} is the momentary temperature above the ambient temperature; the time to reach this is to be calculated,

Θ_o is the starting „overtemperature”,

Θ_n is the reference temperature above the temperature of the environment, which can be measured in steady state, in case of a continuous I_n reference current.

To be able to compare the current–time characteristics of the thermal protection with that of the inverse characteristics, formula (4) can be rearranged using currents and per unit quantities:

$$\frac{t}{T} = \ln \frac{\frac{I^2}{I_{set}^2} - \frac{I_o^2}{I_{set}^2}}{\frac{I^2}{I_{set}^2} - 1} \quad (5)$$

where:

I_o is the continuous current that results Θ_o steady state “overtemperature” at the beginning of the calculation,

I is the current that is applied to reach the steady state Θ_S “overtemperature”,

$$\left(\Theta_S = \frac{I^2 \Theta_n}{I_n^2} \right).$$

I_{set} would be the setting current of the equivalent „overcurrent” function.

The plots according to equation (5) can be seen below. They show how much time is left to reach the „trip temperature” in case of a continuous I (RMS) current. The parameter is the continuous I_o current related to the I_n rated current, which generates the steady state starting temperature. The topmost curve is the „cold curve”.

The plots below clearly show that the thermal replica method “remembers” the starting temperature. If the starting temperature (I_o pre-faulty steady state current) is increased, the time to trip at a fault current $I/I_{set} > 1$ automatically decreases.

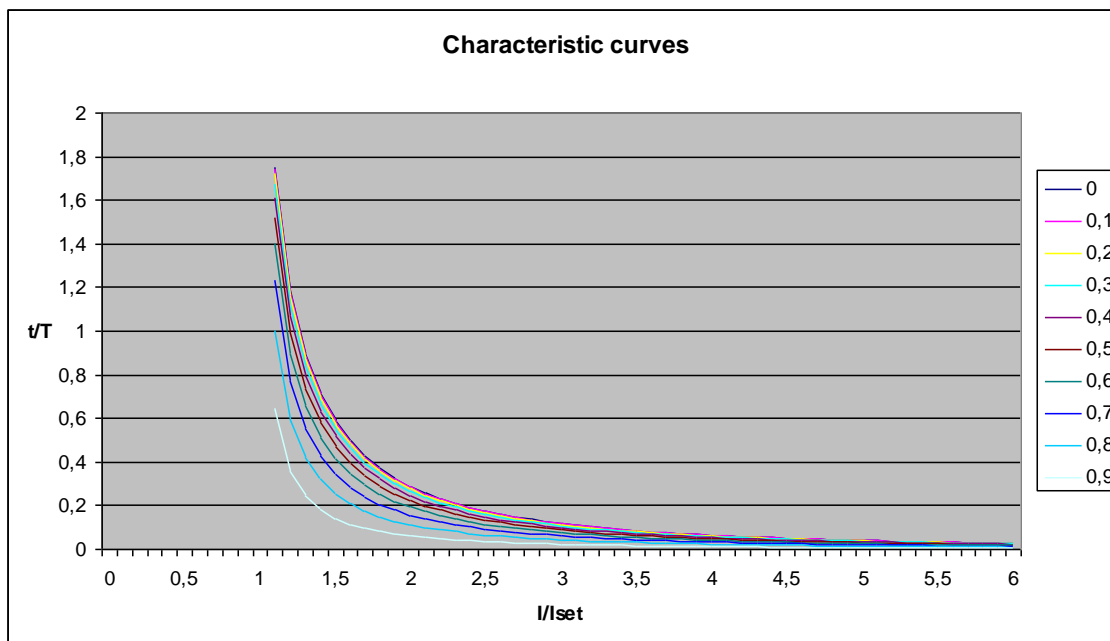

Figure 1-2 Characteristic curves of the line thermal protection function

1.1.4 Numerical solution of the thermal differential equation

The formulas (2-5) above refer to a constant current and can be used to test the thermal protection. In reality, the RMS value of the current changes over time; consequently, differential equation (1) must be solved using a numerical method. The numerical solution is:

$$H_k = \frac{\Theta_k}{\Theta_n} = \left(1 - \frac{\Delta t}{T}\right) \frac{\Theta_{k-1}}{\Theta_n} + \frac{\Delta t}{T} \frac{I^2}{I_n^2} \quad (6)$$

where:

Θ_k is the overtemperature at the k-th calculation step;

Θ_{k-1} is the overtemperature one calculation step before.

1.2 Measurement of the ambient temperature

For a more accurate operation, the function allows for measurement of ambient temperature using a temperature probe, connected through one of the special hardware modules **AIC+** or **RTD+** (see the Hardware Description for more details on these modules). Temperature measurement is activated when the parameter *Temperature sensor* is set to TRUE. The range that the AIC+ module can measure is set by parameter under the **AIC** function block. The **RTD+** module has standard characteristics depending on the type of sensor used.

When a temperature measurement is out of the specified range, the values transmitted to the line thermal protection function also must be carefully evaluated. Below the defined lower range, the thermal protection function defaults to 0 degrees for both modules. Above the defined range, values measured by the module are still transmitted until the module reaches its limit. For broken sensor wires, again the measurement defaults to 0 degrees.

1.3 Structure of the line thermal protection

Fig.1-3 shows the structure of the line thermal protection (TTR49L) algorithm.

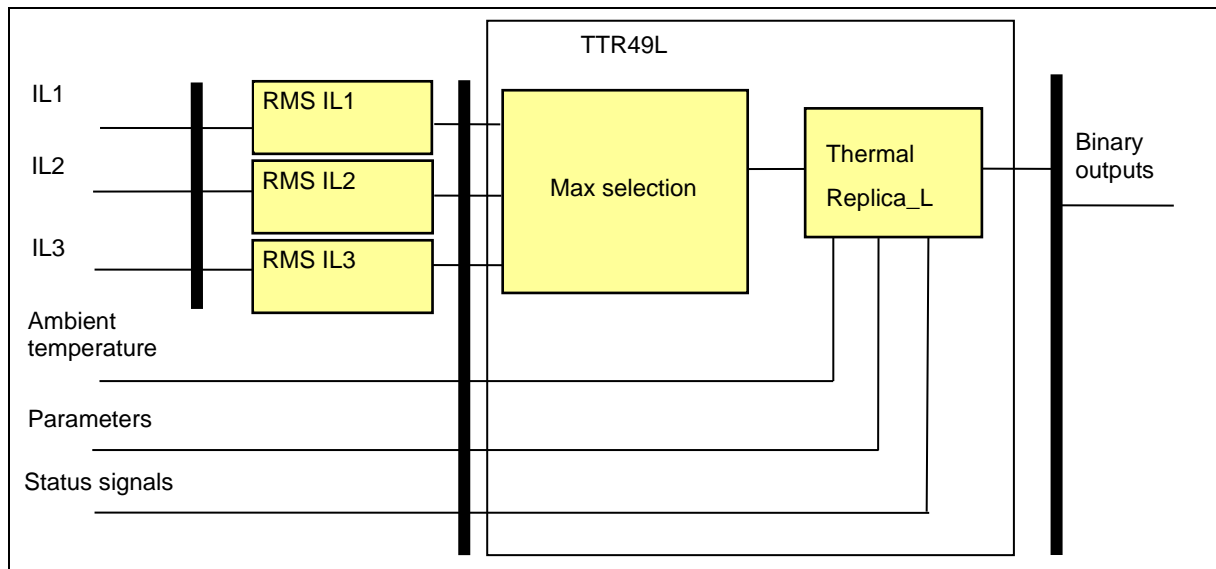

Figure 1-3 The logic scheme of the overcurrent protection function

The **inputs** are

- the RMS values of three primary phase currents,
- optionally the signal proportional to the ambient temperature,
- parameters,
- status signals,

The **outputs** are

- the binary output status signals.

The **software modules** of the line thermal protection function:

RMS calculations

These modules calculate the RMS values of the phase currents individually. The sampling frequency of the calculations is 1 kHz; therefore, theoretically, the frequency components below 500Hz are considered correctly in the RMS values. This module is not part of the Line thermal function; it belongs to the preparatory phase.

Max selection

This module selects the maximal value of the RMS phase currents.

Thermal replica

This module solves the first order thermal differential equation using a simple step-by-step method and compares the calculated temperature to the values set by parameters.

The following description explains the details of the individual components.

1.4 RMS calculation (RMS)

These modules calculate the true RMS values of the phase currents individually. The sampling frequency of the calculations is 1 kHz; therefore, theoretically, the frequency components below 500Hz are considered correctly in the RMS values. This module is not part of the thermal function; it belongs to the preparatory phase.

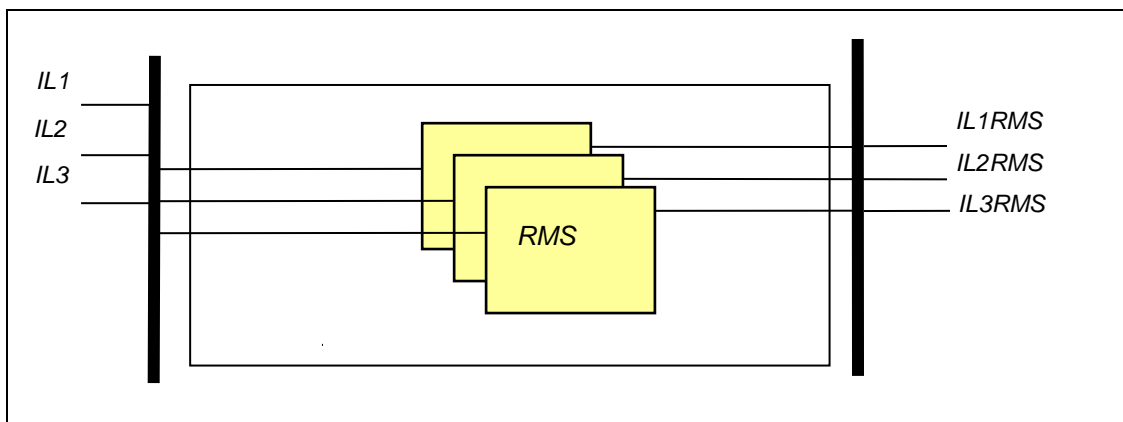

Figure 1-4 The logic scheme of the overcurrent protection function

The **inputs** are the sampled values of the three phase currents ($IL1$, $IL2$, $IL3$)

The **outputs** are the RMS values of the analyzed currents ($IL1RMS$, $IL2RMS$, $IL3RMS$).

1.5 The maximum selection (Max selection)

This module selects the maximum of the three RMS values.

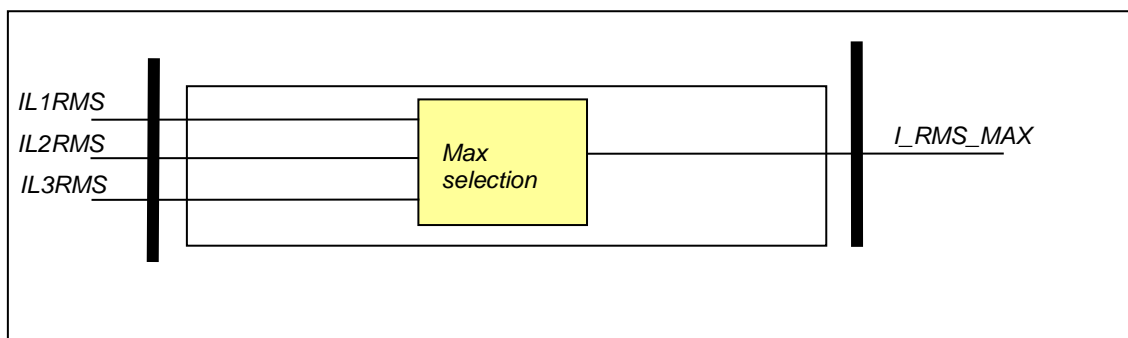

Figure 1-5 Principal scheme of the maximum selection

The **inputs** are the RMS values of the analyzed currents ($IL1RMS$, $IL2RMS$, $IL3RMS$).

The **output** is the selected maximum of the three RMS values.

1.6 The temperature calculation and decision (Thermal replica)

This module solves the first order thermal differential equation using a simple step-by-step method and compares the calculated temperature to the values set by parameters.

The **inputs** are

- The selected maximum of the three RMS values of the phase currents,
- The value proportional to the ambient temperature (this signal is optional, defined at parameter setting),
- Binary input status signals,
- Parameters.

The **outputs** are the status signals. These indicate the generated trip and locked trip command if the temperature is above the setting values.

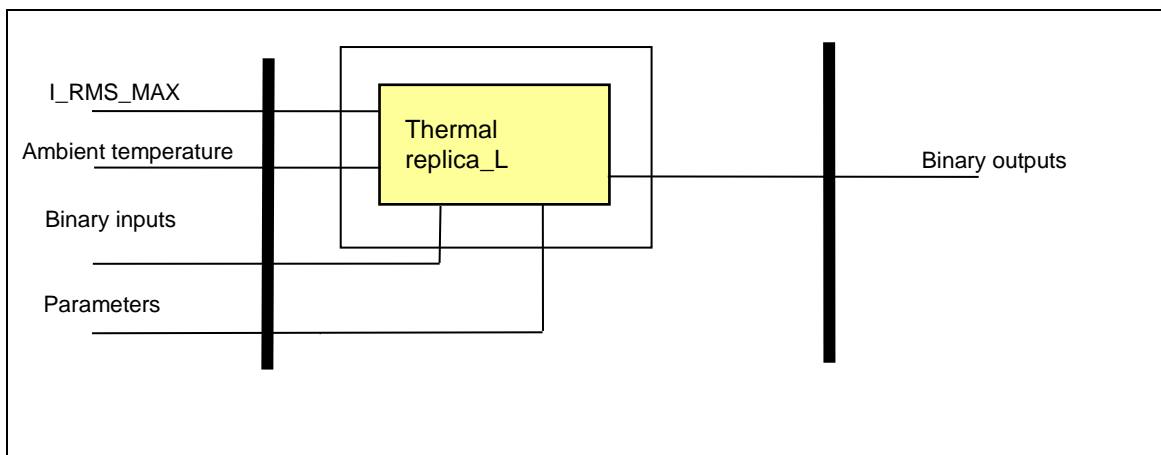

Figure 1-6 Principal scheme of the thermal replica calculation

The function generates an alarm signal if the calculated temperature exceeds the set alarm value. It generates a trip command and activates the locked trip output if the calculated temperature exceeds the trip set value. The locked trip resets in two cases:

- the calculated temperature is decreased under the set value of Unlocked temperature, or
- the IED restarts and the switched off state took longer time than what is defined by the parameter *Temperature memory*. In this case the calculation starts from the preset temperature defined by parameter *Start-up temperature*.

2 Line thermal protection function overview

The graphic appearance of the function block of the line thermal protection function is shown in Figure 2-1. This block shows all binary input and output status signals that are applicable in the graphic equation editor.

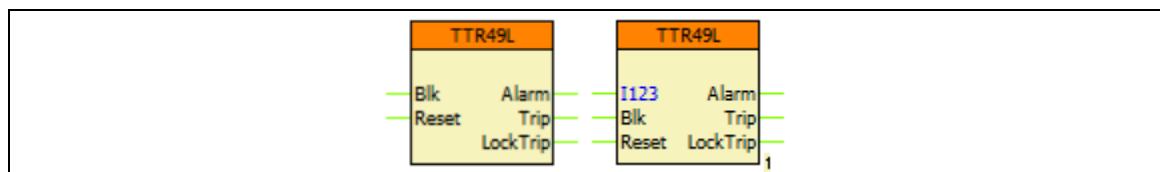

Figure 2-1 The function block of the line thermal protection function

2.1 Settings

2.1.1 Parameters

Table 2-1 Parameters of the line thermal protection function

TITLE	DIM	RANGE	STEP	DEFAULT	EXPLANATION
Operation	-	Off, On	-	Off	Enabling the function. In functionblock version v0 the range was different.
Temperature Sensor	-	FALSE, TRUE	-	FALSE	If this is turned on, the real time ambient temperature will be used for the calculation
Temperature memory	min	0 – 360	1	0	The actual calculated temperature is memorized during the switch off state till the time is set. After that the start-up temperature will be utilized. This parameter exists only from the functionblock version v10.
Rated Load Current	%	20 – 150	1	100	Rated load current of the protected line
Rated Temperature	deg	60 – 200	1	100	Steady state temperature at rated load current
Ambient Temperature	deg	0 – 40	1	25	The temperature of the environment which shall be considered by the function in lack of ambient temperature measurement
Base Temperature	deg	0 – 40	1	25	Ambient temperature during the measurement of the rated values
Start-up Temperature	%	0 – 60	1	0	Initial value for the temperature calculation, related to the rated temperature
Time constant	min	1 – 999	1	45	Measured heating/cooling time constant of the exponential temperature function
Unlock Temperature	deg	50 – 400	1	60	Locked trip signal resets only if the temperature cools below this temperature
Alarm Temperature	deg	50 – 400	1	80	The function generates alarm signal if the calculated overtemperature exceeds this temperature
Trip Temperature	deg	50 – 400	1	100	The function generates trip command if the calculated overtemperature exceeds this temperature

2.2 Function I/O

This section describes briefly the analogue and digital inputs and outputs of the function block.

2.2.1 Analogue inputs

The function uses the sampled values of the three phase currents.

For configurations running on firmware version 2.10.2.3010 and above, i.e. with graphical analogue signals, the table below shows the analogue inputs. Parts written in **bold** are seen on the left side of the function block in the logic editor.

Table 2-2 The graphical analogue input signals of the line thermal protection function

ANALOGUE INPUT SIGNAL	EXPLANATION
TTR49_I123_AnIn_	The calculated RMS value of the three phase current

2.2.2 Analogue outputs (measurements)

Table 2-3 Analogue outputs of the line thermal protection function

ANALOGUE OUTPUT	SIGNAL TITLE	EXPLANATION
TTR49L_Temp_OLM_	Calculated Temperature	The temperature value, which is calculated from the equations above

2.2.3 Binary output signals (graphed input statuses)

The **binary output status signals** of the line thermal protection function are listed in Table 2-4. **Parts** written in **bold** are seen on the function block in the logic editor.

Table 2-4 The binary output status signals of the line thermal protection function

BINARY OUTPUT SIGNALS	SIGNAL TITLE	EXPLANATION
TTR49L_Alarm_Grl_	Alarm	Alarm signal of the line thermal protection function
TTR49L_Trip_Grl_	Trip	General trip signal of the line thermal protection function
TTR49L_LockTrip_Grl_	Locked Trip	The Locked Trip output is set at the same time when the Trip output is set, but it is reset only when the calculated overtemperature decreases below the value set by parameter <i>Unlock Temperature</i>

2.2.4 Binary input signals (graphed output statuses)

The line thermal protection function has two binary input signals. One of them serves the purpose of disabling the function; the other one resets the accumulated heat. Resetting serves test purposes only, if the heating calculation needs to start at a clearly defined temperature. Using this signal, the test engineer does not need to wait until the temperature reaches an initial value again by the subsequent heating test. The calculation will start in this case from the value set by the parameter *Start-up Temperature*.

Both binary input status signals are defined by the user, applying the graphic equation editor.

Table 2-5 The binary input status signals of the line thermal protection function

BINARY INPUT SIGNAL	EXPLANATION
TTR49L_Blk_GrO_	Signal for blocking the function
TTR49L_Reset_GrO_	Signal for resetting the function

2.2.5 On-line data

Visible values on the on-line data page:

Table 2-6 On-line data of the line thermal protection function

SIGNAL TITLE	DIMENSION	EXPLANATION
Calculated Temperature	deg	The temperature which is calculated by the thermal equations above

2.2.6 Events

The following events are generated in the event list, as well as sent to SCADA according to the configuration.

Table 2-7 Events of the line thermal protection function

EVENT	VALUE	EXPLANATION	IEC61850 DATA ATTRIBUTES
Alarm	off, on	If the calculated temperature reaches the Alarm temperature, the value of the event become "on"	TOPTTR49L\$ST\$AlmThm
General Trip	off, on	If the calculated temperature reaches the Trip temperature, the value of the event become on	TOPTTR49L\$ST\$Op

2.3 Technical data

Table 2-8 Technical data of the line thermal protection function

FUNCTION	VALUE	ACCURACY
Operate time at $I > 1.2 \cdot I_{trip}$	Parameter values	< 3 % or <+ 20 ms

* Measured with signal relay contact

2.4 Notes for testing

Normally in the EuroProt+ devices the trip contacts are assigned to the Trip Logic function block, and not to the protection function blocks. Because of this, the testing personnel must make sure that the Trip Logic is switched on ('Operation' parameter is set to other than 'Off') before starting the testing, otherwise there will be no physical trip on the relay.

For the accurate measurement of the tripping time, it is suggested to reset the function or restart the device before starting the current injection. Depending on the set value of the parameter *Temperature memory* and the time of switched off state, the calculation will start from the last calculated value before switching off or from the set value of parameter *Start-up Temperature*.