

## FUNCTION BLOCK DESCRIPTION

# Three-phase Instantaneous Overcurrent Protection

ANSI 50, IEC I>>>



DOCUMENT ID: PP-13-22489  
VERSION: 3.0  
2025-01-17, BUDAPEST

PROTECTION, AUTOMATION AND  
CONTROL FOR POWER INDUSTRY



## VERSION INFORMATION

VERSION	DATE	MODIFICATION	COMPILED BY
Preliminary	2009-10-30	Preliminary version, without technical information	Petri
	2010-06-18	Technical information added	Petri
	2010-10-05	Naming revision	Csipke
1.0	2010-11-11	First edition	Petri
2.0	2022-03-03	New design, new chapters (overview, notes for testing) added	Saina, Erdős
3.0	2025-01-17	Graphical analogue inputs added, IEC61850 info added	Erdős

## CONTENTS

1	Application .....	4
1.1	Operating Characteristics .....	4
1.2	Structure of the Protection Algorithm .....	5
1.3	The Fourier Calculation ( <u>Fourier</u> ) .....	6
1.4	The Peak Selection ( <u>Peak selection</u> ).....	6
1.5	The Instantaneous Decision ( <u>Instantaneous decision</u> ).....	7
1.6	The Decision Logic ( <u>Decision logic</u> ) .....	9
2	3-Phase Instantaneous OC Function Overview .....	10
2.1	Settings .....	10
2.1.1	Parameters .....	10
2.2	Function I/O.....	11
2.2.1	Analogue inputs .....	11
2.2.2	Binary input signals (graphed output statuses) .....	11
2.2.3	Binary output signals (graphed input statuses) .....	11
2.2.4	Online data .....	12
2.2.5	Events.....	12
2.3	Technical Data .....	13
2.4	Notes for Testing.....	13

## 1 Application

The instantaneous overcurrent protection function operates according to instantaneous characteristics, using the three sampled phase currents. The setting value is a parameter, and it can be doubled by graphic programming of the dedicated input binary signal.

The basic calculation can be based on peak value selection or on Fourier basic harmonic calculation, according to the parameter setting. When Fourier calculation is selected then the accuracy of the operation is high, the operation time however is above one period of the network frequency. If the operation is based on peak values, then fast sub-cycle operation can be expected, but the transient overreach can be high.

### 1.1 Operating Characteristics

$$t(I) = t_{OP} \text{ when } I > I_S$$

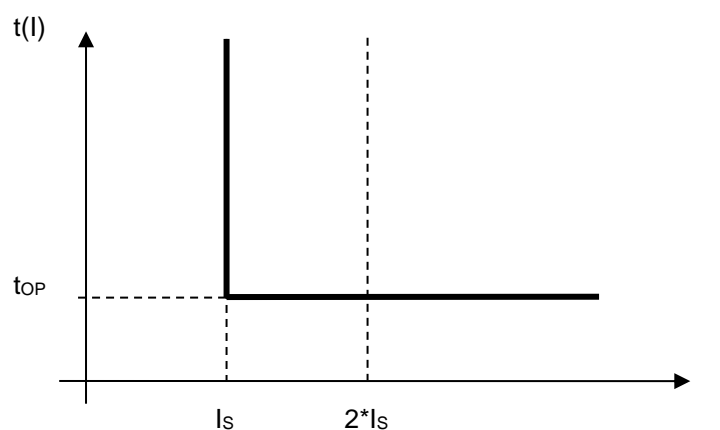

Figure 1-1 Overcurrent independent time characteristic

where:

- $t_{OP}$  (sec.)      theoretical operating time if  $I > I_{Gs}$  (without additional time delay),
- $I$                       measured value of the characteristic quantity, peak values or Fourier base harmonic of the phase currents,
- $I_s$                       setting value of the characteristic quantity (*Start current*)

## 1.2 Structure of the Protection Algorithm

Figure 1-2 shows the structure of the instantaneous overcurrent protection (IOC50) algorithm.

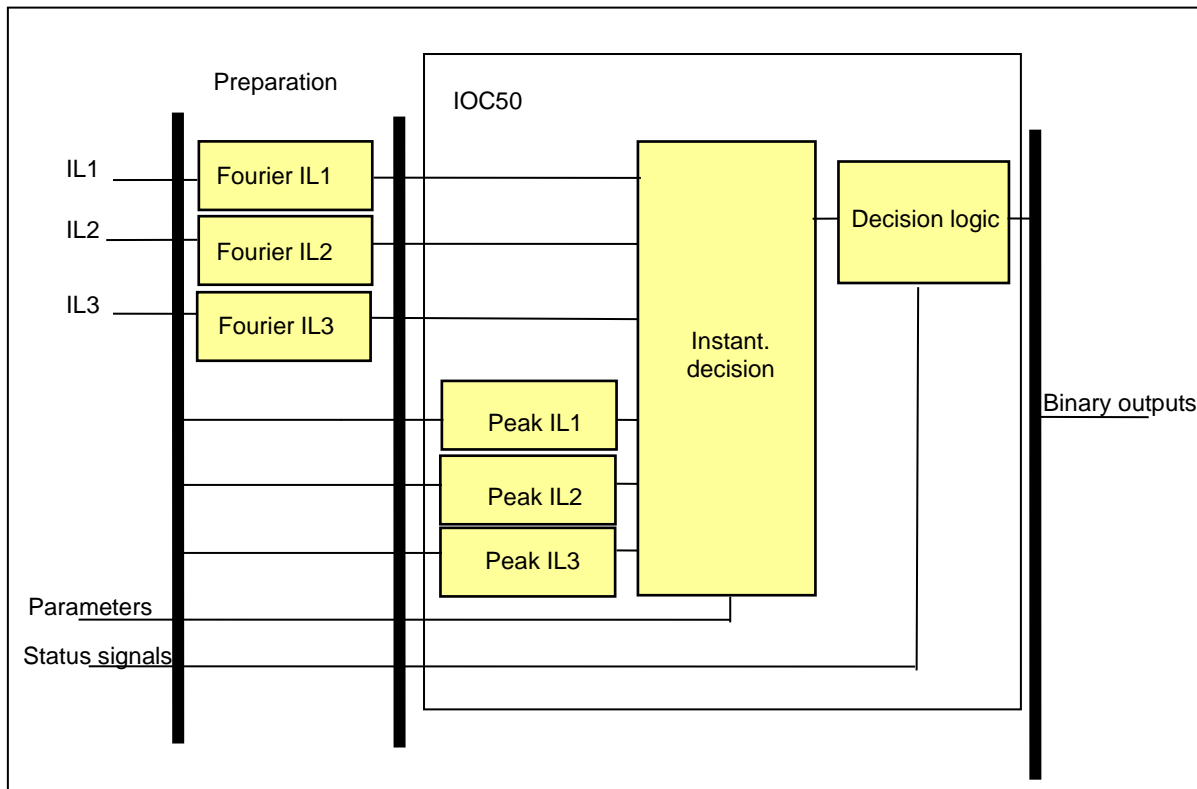

Figure 1-2 Structure of the instantaneous overcurrent protection algorithm

The **inputs** are

- the sampled values of three phase currents,
- the RMS values of the fundamental Fourier component of three phase currents,
- parameters,
- status signals.

The **outputs** are

- the binary output status signals.

The **software modules** of the three-phase instantaneous overcurrent protection function are:

### **Fourier calculations**

These modules calculate the RMS values of the fundamental Fourier component of three phase currents individually (not part of the IOC50 function).

### **Peak selection**

These modules select the peak values of the phase currents individually.

### **Instantaneous decision**

This module compares the peak value or the Fourier basic harmonic components of the phase currents with the setting value.

### **Decision logic**

The decision logic modules generate the trip command of the function.

### 1.3 The Fourier Calculation (Fourier)

The following description explains the details of the individual components.

These modules calculate the RMS values of the fundamental Fourier component of the three phase currents individually. They are not part of the IOC50 function; they belong to the preparatory phase.

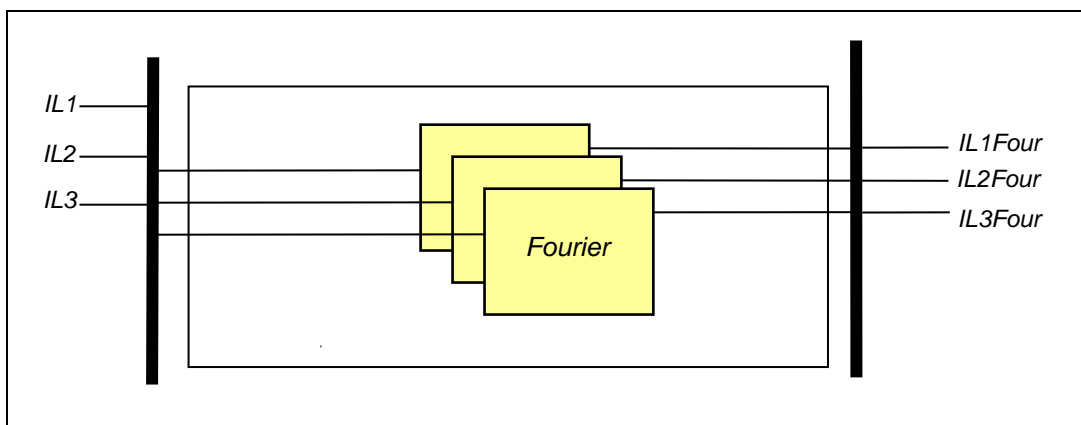

Figure 1-3 Principal scheme of the Fourier calculation

The **inputs** are the sampled values of the three phase currents (IL1, IL2, IL3).

The **outputs** are the RMS values of the fundamental Fourier component of three phase currents (IL1Four, IL2Four, IL3Four).

### 1.4 The Peak Selection (Peak selection)

These modules select the peak values of the phase currents individually.

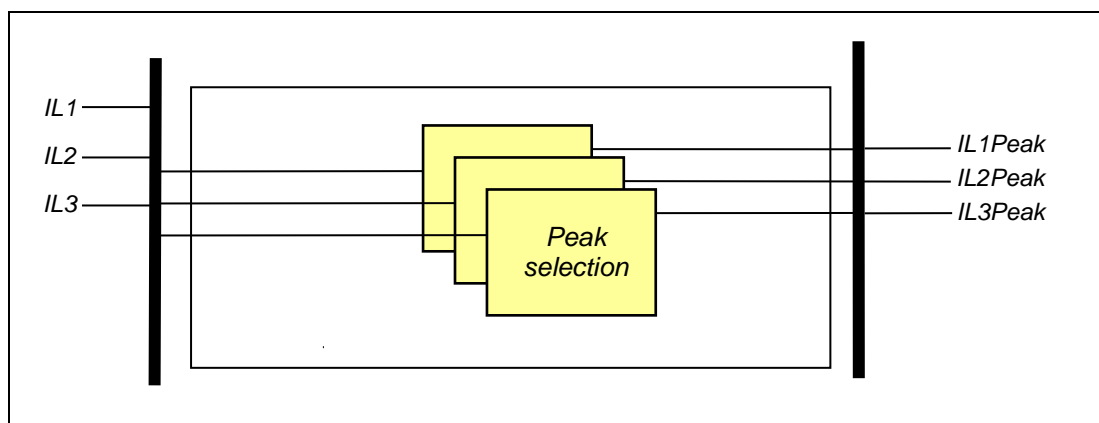

Figure 1-4 Principal scheme of the peak selection

The **inputs** are the sampled values of the three phase currents (IL1, IL2, IL3).

The **outputs** are the peak values of the analyzed currents (IL1Peak, IL2 Peak, IL3 Peak).

## 1.5 The Instantaneous Decision (Instantaneous decision)

This module generates trip commands for the phases without additional time delay based on the Fourier components of the phase currents or based on the peak values, if the detected values are above the current setting value.

The **inputs** are the RMS values of the fundamental Fourier component of three phase currents (IL1Four, IL2Four, IL3Four), the peak values (IL1Peak, IL2 Peak, IL3 Peak), parameters and status signals.

The **outputs** are the status signals of the three phases individually. These indicate the generated trip commands if the currents are above the current setting value.

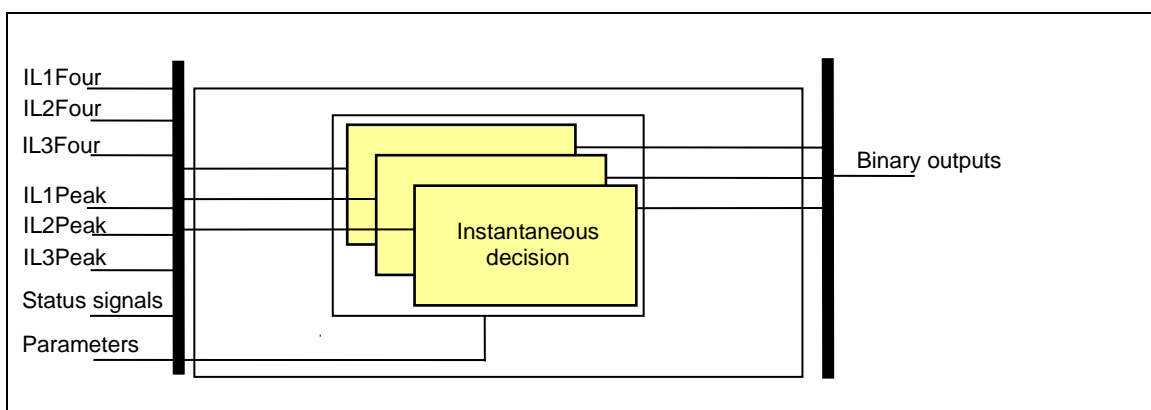

Figure 1-5 Principal scheme of the instantaneous characteristic calculation

## Enumerated parameters

Table 1-1 The enumerated parameters of the instantaneous OC protection function

TITLE	DIM	RANGE	STEP	DEFAULT	EXPLANATION
Operation	-	Off, Peak value, Fundamental value	-	Off	Parameter for enabling the function and selection type.

## Integer parameters

Table 1-2 The integer parameter of the instantaneous OC protection function

TITLE	DIM	RANGE	STEP	DEFAULT	EXPLANATION
Start Current	%	20 – 3000	1	200	Start setting of the function. If the current exceeds this value, the function picks up and trips after the minimum operation time of the relay ( $t_{OP}$ ).

## Binary status signals

The decision block of the instantaneous overcurrent protection function has binary input signals, which serve the purpose of blocking the function and doubling the setting value of the function. **The conditions are defined by the user, applying the graphic equation editor.**

Table 1-3 The binary input signals for the decision block of the IOC protection function

BINARY STATUS SIGNAL	SIGNAL TITLE	EXPLANATION
IOC50_Blk_GrO_	Block	Input for disabling the function
IOC50_Double_GrO_	Double	Input used to double the value of the parameter "Start Current".

The **binary output status signals** of the three-phase instantaneous overcurrent protection function are listed in Table 1-4 below.

Table 1-4 The binary output status signals of the IOC protection function

BINARY OUTPUT SIGNAL	SIGNAL TITLE	EXPLANATION
IOC50_TrL1_GrI_	Trip L1	Trip command of the function in phase L1
IOC50_TrL2_GrI_	Trip L2	Trip command of the function in phase L2
IOC50_TrL3_GrI_	Trip L3	Trip command of the function in phase L3

## 1.6 The Decision Logic (Decision logic)

The decision logic module combines the status signals to generate the general trip command of the function.

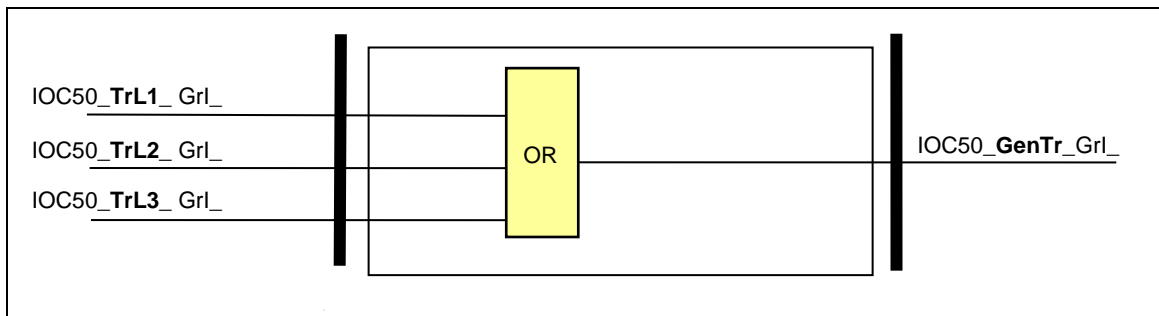

Figure 1-6 The logic scheme of the instantaneous overcurrent protection function

Table 1-5 The binary input status signals of the decision logic

BINARY INPUT SIGNAL	SIGNAL TITLE	EXPLANATION
IOC50_TrL1_Grl_	Trip L1	Trip command of the function in phase L1
IOC50_TrL2_Grl_	Trip L2	Trip command of the function in phase L2
IOC50_TrL3_Grl_	Trip L3	Trip command of the function in phase L3

Table 1-6 The binary output status signal of the decision logic

BINARY OUTPUT SIGNAL	SIGNAL TITLE	EXPLANATION
IOC50_GenTr_Grl_	General Trip	General trip command of the function

## 2 3-Phase Instantaneous OC Function Overview

The graphic appearance of the 3-phase instantaneous overcurrent protection function block is shown in Figure 2-1. This block shows all binary input and output status signals that are applicable in the graphic equation editor.

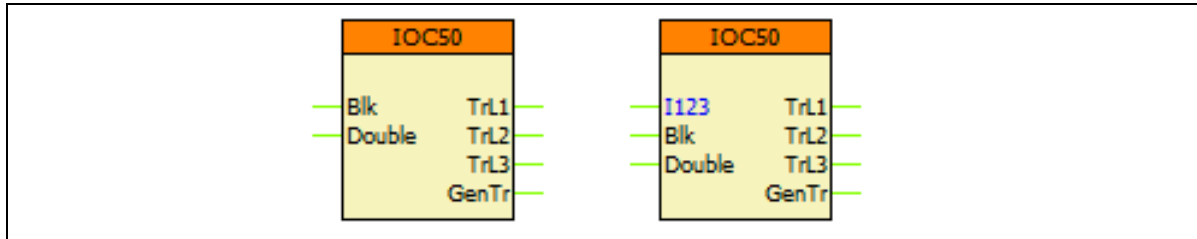

Figure 2-1 The function block of the 3-phase instantaneous overcurrent protection

### 2.1 Settings

#### 2.1.1 Parameters

The available parameters are listed below in order of their appearance in the *parameters* menu. If the setting range of a parameter should be extended, contact Protecta Support.

Table 2-1 Parameters of the 3-phase instantaneous overcurrent protection function

TITLE	DIM	RANGE	STEP	DEFAULT	EXPLANATION
Operation	-	Off, Peak value, Fundamental value	-	Off	Parameter for enabling the function and selection type.
Start Current	%	20 – 3000	1	200	Start setting of the function. If the current exceeds this value, the function picks up and trips after the minimum operation time of the relay ( $t_{OP}$ ).

## 2.2 Function I/O

This section briefly describes the analogue and digital inputs and outputs of the function block.

### 2.2.1 Analogue inputs

The analogue inputs are the RMS values of the fundamental Fourier component of the three phase currents.

#### Graphic Analogue inputs (*only from firmware version 2.10.2.3010 and up*)

The sources of the analogue inputs are defined by the user, applying the graphic equation editor (*Logic Editor*). Parts written in **bold** are seen on the left side of the function block in the Logic editor.

The function uses the following analogue signals as inputs:

Table 2-2 Analogue input signal of the 3ph IOC function

ANALOGUE INPUT SIGNAL	SIGNAL TITLE	EXPLANATION
IOC50_ <b>I123</b> _AnIn_	3phase current	Analogue input for three-phase current

The applied analogue connectors must be identical to the analogue input type (i.e. voltage to voltage input etc.), invalid connections are not allowed.

### 2.2.2 Binary input signals (graphed output statuses)

The conditions of the binary inputs are defined by the user, applying the graphic equation editor (*Logic Editor*). Parts written in **bold** are seen on the left side of the function block in the Logic editor.

Table 2-3 The binary input signals of the 3ph IOC function

BINARY INPUT SIGNAL	SIGNAL TITLE	EXPLANATION
IOC50_ <b>Blk</b> _GrO_	Block	Input for disabling the function
IOC50_ <b>Double</b> _GrO_	Double	Input used to double the value of the parameter "Start Current".

### 2.2.3 Binary output signals (graphed input statuses)

These signals can be used in EuroCAP to assign to LED, user LCD object etc. Parts written in **bold** are seen on the right side of the function block in the *Logic Editor*.

Table 2-4 The binary output signals of the 3ph IOC function

BINARY OUTPUT SIGNAL	SIGNAL TITLE	EXPLANATION
IOC50_ <b>TrL1</b> _GrI_	Trip L1	Trip command of the function in phase L1
IOC50_ <b>TrL2</b> _GrI_	Trip L2	Trip command of the function in phase L2
IOC50_ <b>TrL3</b> _GrI_	Trip L3	Trip command of the function in phase L3
IOC50_ <b>GenTr</b> _GrI_	General Trip	Trip command of the function in at least one of the three phases

## 2.2.4 Online data

The following values are visible in the *online data* page.

Table 2-5 Online data of the 3ph IOC function

SIGNAL TITLE	DIMENSION	EXPLANATION
Trip L1	-	Trip command of the function in phase L1
Trip L2	-	Trip command of the function in phase L2
Trip L3	-	Trip command of the function in phase L3
General Trip	-	Trip command of the function in at least one of the three phases
<i>Current input assignment</i>	-	<i>Status of the graphical analogue input (if exists) (Complete if OK, Missing if not connected)</i>

## 2.2.5 Events

The following events are generated in the event list, as well as sent to the SCADA according to the configuration.

Table 2-6 Generatable events of the 3ph IOC function

EVENT	VALUE	EXPLANATION	IEC61850 DATA ATTRIBUTES
General Trip	off, on	Trip command of the function in at least one of the three phases	F3PIOC1\$Op\$general
Trip L1	off, on	Trip command of the function in phase L1	F3PIOC1\$Op\$phsA
Trip L2	off, on	Trip command of the function in phase L2	F3PIOC1\$Op\$phsB
Trip L3	off, on	Trip command of the function in phase L3	F3PIOC1\$Op\$phsC

## 2.3 Technical Data

Table 2-7 Technical data of the 3-phase IOC protection function

FUNCTION	VALUE	ACCURACY
<i>Using peak value calculation</i>		
Operating characteristic	Instantaneous	< 6%
Reset ratio	0.85	
Operate time at 2*Is	< 15 ms	
Reset time*	< 40 ms	
Transient overreach	90%	
<i>Using Fourier fundamental harmonic calculation</i>		
Operating characteristic	Instantaneous	< 2%
Reset ratio	0.85	
Operate time at 2*Is	< 25 ms	
Reset time*	< 60 ms	
Transient overreach	15%	

\* Measured with signal contacts

## 2.4 Notes for Testing

Normally in the EuroProt+ devices the trip contacts are assigned to the Trip Logic function block, and not to the protection function blocks. Because of this, the testing personnel must make sure that the Trip Logic is switched on ('Operation' parameter is set to other than 'Off') before starting the tests, otherwise there will be no physical trip on the relay.

Being an instantaneous function, its connection to the Trip Logic function is done in the Fast Equations (by default) and not in the Logic Editor (usually, there are comments inserted in the Logic Editor if such connections exist). This can be checked in EuroCAP.

The analogue sources can be changed by the user (i.e. if there are multiple CT modules in a device, it might be possible to assign the measurements of either CT module to the function's inputs). This can be checked in the function block properties in EuroCAP.

### Additional notes for Graphic Analogue inputs (*only from firmware version 2.10.2.3010 and up*):

Starting from the firmware version **2.10.2.3010**, the majority of the function blocks can be updated to be equipped with graphic analogue inputs which **allow the user to assign the functions' analogue inputs by applying the graphic equation editor**.

The analogue connections of these functions can be checked by examining the source that is connected to their inputs (just like examining the source of a logic signal).

These functions must be placed in the Logic Editor and their graphic analogue inputs must be connected to make them operate. If a connection is intact, the online status of the corresponding analogue input will show "Complete". If it is missing, the status will be "Missing" and the function will not operate.

*Note that these graphical inputs do not exist in the earlier firmware/function versions! Checking and modifying the analogue assignments in these cases are done by using the EuroCAP Software Configuration menu.*