

DGSZV-EP

DIGITAL GALVANIC LONGITUDINAL DIFFERENTIAL PROTECTION

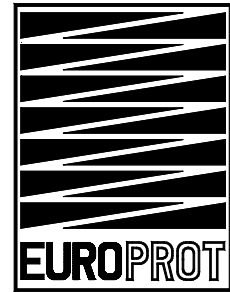

The digital galvanic longitudinal differential protection of type **DGSZV-EP** is part of device family named *EuroProt*. This short description contains special data of this type. General and common features of *EuroProt* family can be found in the *EuroProt* system information sheet. Accordingly it is proposed to study both this short description and system information sheet too, in order to understand the device entirely.



Application field

The DGSZV-EP type digital galvanic longitudinal differential protection of can be applied in electric power generating plants, transmission and distribution substations of the electric power system to quick and selectively protect high or medium voltage lines or cables against phase or ground faults.

There are basically three versions:

- a three phase version for effectively grounded networks,
- a two phase device to protect medium voltage compensated or isolated networks against phase faults,

- in medium voltage resistance grounded or compensated network with neutral resistor for increasing the earth fault current, against phase and ground faults.

The protection needs a single-phase, three wires, galvanic connection between the devices of both ends of the line. The connection is continuously supervised, in case of failure an alarm signal is generated, and disables or submits a trip command, according to the parameter setting.

Main features

The **DGSZV-EP** type digital galvanic longitudinal differential protection is member of the numeric device family of PROTECTA Co. Ltd., called *EuroProt*.

The protection contains a differential measuring element of a percentage bias characteristic with settable basic sensitivity (ΔI), an overcurrent function measuring in two phases ($I > (t)$ and $I >> (t)$), four basic and two additional, free applicable timers (T1, T2).

The stages of the galvanic longitudinal differential protection and overcurrent functions can be enabled independently of each other. The parameters for the differential protection, the current and the voltage elements and the timers can be set independently.

The length of the single phase, three line, galvanic connection between the devices at both ends, in case of copper conductor may be maximum 10 km, the cross-section must be at least 1,5 mm².

The three phase basic version of the device can be applied connected to two phases, or two phases + Io as well.

The trip command can depend on undervoltage state. The phase selection is decided by the undervoltage function, but it is not absolutely necessary. The characteristics with two knee points can be set as needed, the biasing is made with the average of absolute value of currents at both ends.

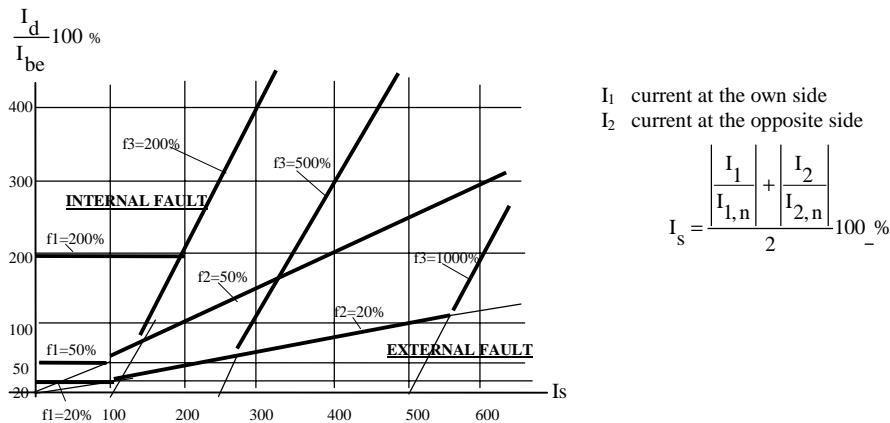

The trip characteristics of the digital galvanic longitudinal differential protection

The operating time of the differential protection is approx. 35 ms.

Software characteristics:

- built-in self-check functions,
- digital event recorder for 50 events, and an event sequence recorder with 1 ms time resolution for maximum 300 events,
- analog event records with current data,
- two additional timers (T1 and T2) in connection with the software matrix,
- the rows of the matrix (the relay-functions) can be latched.

Hardware characteristics:

- numerical type, with own A/D converter, digital signal processor (DSP) and separate main processor,
- 8 opto-coupler inputs,
- 16 output contacts,
- the type of the contacts (NC or NO) can be selected individually for each contacts when ordering,
- versions for 19" rack cabinet mounting or housed in relay case (semi-flush mounting or hinged type).

Communication:

- 2x16 character LCD display for setting the functions, displaying messages and reading event records,
- on-line screen on external PC to make commissioning and testing easier,
- external communication interface, can be set for RS 232 or for fibre optic cable,

- optional interface module with IEC 870 protocol for SCADA systems,
- the set parameters can be saved and downloaded,
- real time clock handling with the aid of RAM with battery, (which can be synchronised via optical fibre cable connected to external PC, to the SCADA system, or through an optical cable).

Working principle

The **DGSZV-EP** device is a fully microprocessor based construction, the functions and their versions are realised basically on software.

The device contains a 87C196 type 16 bit micro-controller. The program is stored in the internal EPROM of the controller, the message text for the display is stored in EPROM as well. The parameter setting is loaded in EEPROM. Events are recorded in battery supplied RAM. The man-machine interface consists of a keyboard with six push-buttons, above it the two row, 2 x 16 character LCD display, seven LEDs and two SW pushbuttons. With the help of an external PC and communication software the handling of the device is easier.

The analog current and voltage inputs are connected via inductive internal measuring transformers and low-pass filters to the multiplexer then to the A/D converter, where all current and voltage signals are sampled in every 0,5 ms. The sampled values of the 16 bit A/D converter are passed via high speed CAN bus to the CPU. The central processor communicates via parallel bus with the optocoupler inputs and with the relay drivers.

The protection contains a two stage definite time overcurrent protection for all the three phases. The time delay of all stages can be set independently. The two overcurrent stages contain RMS algorithm, the setting of the stages is independent of each other.

The longitudinal differential protection function compares currents of the own end and that of the far end, composed of the weighted (2x, 3x, 1x) three phase currents or composed of two weighted phase currents and the zero sequence current (See Figure below), and decides if the fault is inside the protected section and a trip command is issued, or the fault is outside, when no trip command is generated. The algorithm compares 10 subsequent sampled values, then the comparison is repeated one period later. If the evaluation shows twice difference, the trip command is generated. The I_d trip signal is composed of the vector difference of the single phase currents of the two sides, the restraint current is the average of the measured individual currents.

As because of the presence of the intermediate current transformers and the connecting pilot cable, the saturation effects can be expected at smaller currents, the f3 knee point of the characteristics must be set lower, than that of the usual differential protection (see Figures). One branch of the pilot cable is for the current proportional to the own current, the second is for that of the opposite line side, the third branch is for the sum of these currents (I_d).

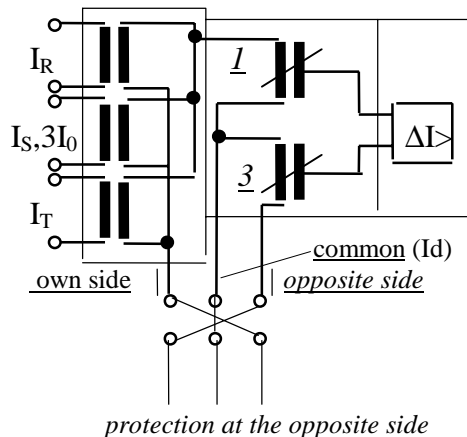

Scheme of the longitudinal differential protection

The pilot cable is supervised in the operating current range by a sensitive differential function. The disabling (and the safety trip command if this is set by parameters) is delayed, if there is no deviation, a drop delay is set. The trip command can depend of voltage precondition, in this case the protection submits warning signal only. The longitudinal distance protection function, if voltage precondition is set, is blocked by the open signal of the miniature circuit breakers in the voltage transformer's secondary circuit.

The galvanic longitudinal differential protection contains intermediate current transformers, and depending on the turns ratios of the mixing current transformers - at the rated current 5 A and 1 A as well - the current in the pilot cable is between 20 mA and 40 mA. One branch of the pilot cable is for the current proportional to the own current, the second is for that of the opposite line side, the third branch is for the sum of these currents (I_d). In case of load current, or in case of external faults this branch has double current sum. This makes possible a quick and simple supervision.

Technical data

Rated secondary current, I_n	1A or 5 A
Rated voltage (line), U_n	100V or 200 V
Rated frequency	50 Hz or 60 Hz
Overload capacity, voltage circuit, thermal, continuous	$2 \times U_{\text{phase}} = 2 \times U_n / \sqrt{3}$
current circuit, thermal, continuous 1 s	$4 \times I_n$ 100x I_n (if $I_n = 1$ A) 50x I_n (if $I_n = 5$ A)
Dynamic current limit	100x I_n
Accuracy, current relays (above 50 % I_n)	± 2 %
Accuracy timers, with 10 ms steps with 1 s steps	± 3 ms ± 12 ms
Reset ratio, current relays	95 %
Number of output relays	12 print relays
Type of contacts (NO / NC):	<i>to be selected at ordering, factory setting 1 NC 11 NO</i>
Output contacts, electrical data: rated switching voltage continuous load current making current DC breaking capability at 220 V, at pure conductive load at load of L/R = 40 ms <i>option</i> at load of L/R = 40 ms	250 V 8 A 16 A 0,25 A 0,14 A 4 A
Auxiliary DC voltage (the same supply unit) voltage tolerance	220 V or 110 V 88...310 V
Permissible ambient temperature	0° ...50° C
Insulation test (IEC 255)	2 kV, 50 Hz 5 kV, 1,2/50 μ s
Disturbance test (IEC 255)	2,5 kV, 1 MHz
Electrostatic discharge (ESD, IEC 801-2)	8 kV
Burst test (IEC 801-4)	2 kV
Setting ranges	
Basic setting ($I_d > f1 * I_{be}$)[f1]	10...200 %, step: 2 %
Slope of section 2. ($I_d > f2 * I_s$)[f2]	40...80 %, step: 2 %
Slope of section 3. ($I_d > 2I_s - f3 * I_{be}$)[f3]	50...2000 %, step: 10 %
Voltage condition [$U > U_n$]	20...100 %, step: 5 %
The tertiary rated current at the own side ($I_{set[own]}$ rated.)	0,2 A fix
The tertiary rated current at the opposite side ($I_{set[opp]}$ rated.)	0,2 A fix
Delay of signalling cable error	0...64000 ms, step 10 ms

Low set overcurrent function, $I_{>} / I_n[AV]$	50...2500 %, step: 5 %
High set overcurrent function, $I_{>>} / I_n[AV]$	50...2500 %, step: 5 %
CT rated primary current, $I_n[AV]$	50...2500 A, step: 25 A
External communication type	RS 232 or fibre optic cable
Serial communication Baud rate	150...19200 Baud
Optical fibre cable operation mode	Radial or loop
Daily automatic self-check time	23 hours 59 min.(step 1 min)
Automatic self-check block	setting 60 min

Design, size

An **EuroProt** device is always rack mounted, it has two design forms. One of the form is suitable to be mounted into standard 19" cabinet frame, this form is also suitable to be mounted directly to a relay panel with flash mounted form. The other form is a relay panel mounted device with raised-hinged form.

Outline size of 19" cabinet frame mounted device:

Width	Height	Depth
483 mm	132,5 mm	201 mm

Outline of the panel mounted device with raised-hinged form:

Width	Height	Depth
490 mm	250 mm	250 mm

Weight: 8 kg.

Options

The device can be extended by optional units:

- digital disturbance recorder (see separate information sheet),
- SCADA connection (see *EuroProt* system information sheet),
- output relays with 4 A breaking capability.

Information required with order

- Protection type [DGSZV-EP],
- Protection case type [19" cabinet frame mounted device, or panel mounted device
- Rated current [1 A, 5 A],
- Rated voltage [100 V, 200 V],
- Output relay contact type [NC or NO, if deviates from the *Technical Data*],
- Options if needed

